

Fontaine® Fifth Wheel Ultra NT

Rebuild Procedures

- Disassembly
- Assembly
- Adjustments



FONTAINE®
PARTS CONNECTION

www.fifthwheel.com • 800-874-9780

Cover plate removed for clarity. Refer to exploded view of assembly on page 6 to identify item number and parts.

Degrease fifth wheel before installing new parts

1. Remove springs and pull handle

Remove secondary lock handle spring (11) and bumper spring (12). Remove pull handle cotter pin (28) and washer (27) then slide out pull handle (26).

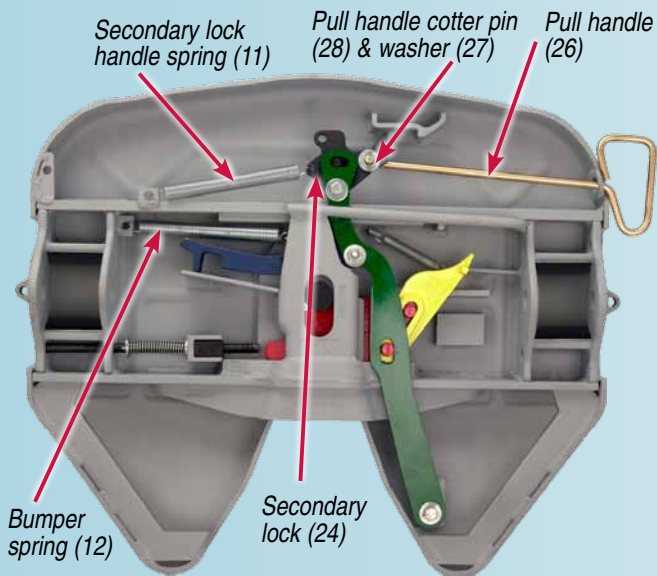

Note: 7000 top plate shown, but similar to Ultra NT

2. Remove secondary lock

Unbolt and remove secondary lock (24) from operating handle (38). Discard lock nut and bushing.

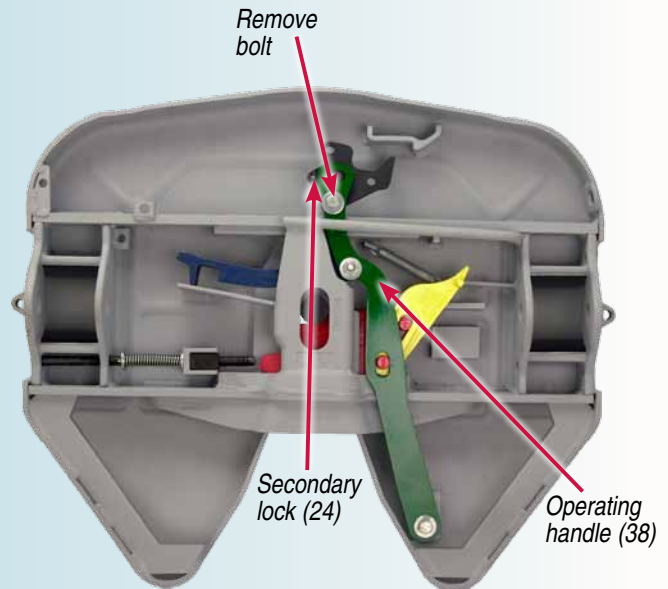

3. Remove bumper from operating handle

Unbolt and remove bumper (33) from operating handle (38). Discard lock nut and bushing.

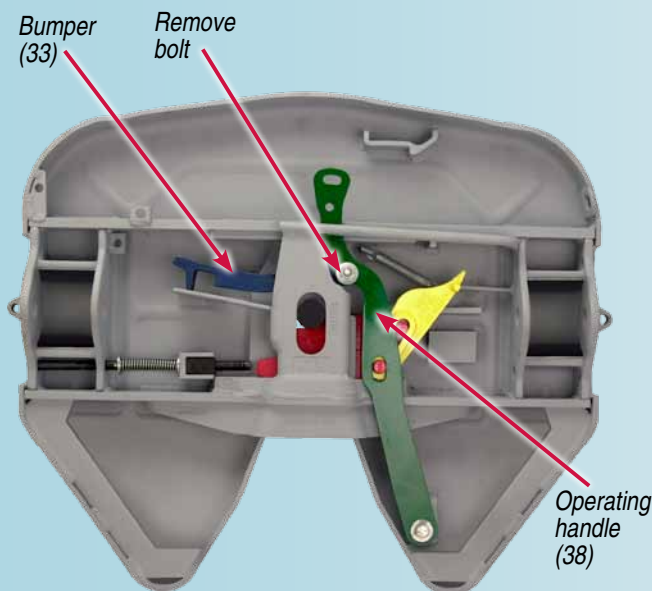

4. Remove operating handle

Unbolt operating handle (38) from pivot mount and remove. Discard lock nut.

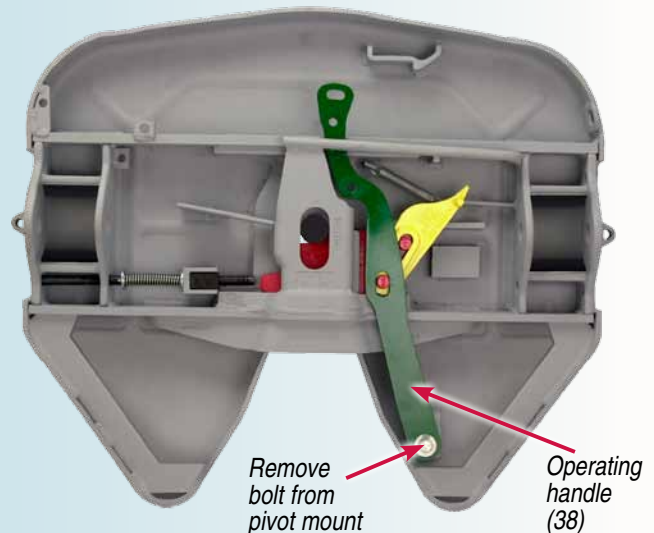

Cover plate removed for clarity. Refer to exploded view of assembly on page 6 to identify item number and parts.

5. Remove timer

Remove timer spring (34) and timer (37).

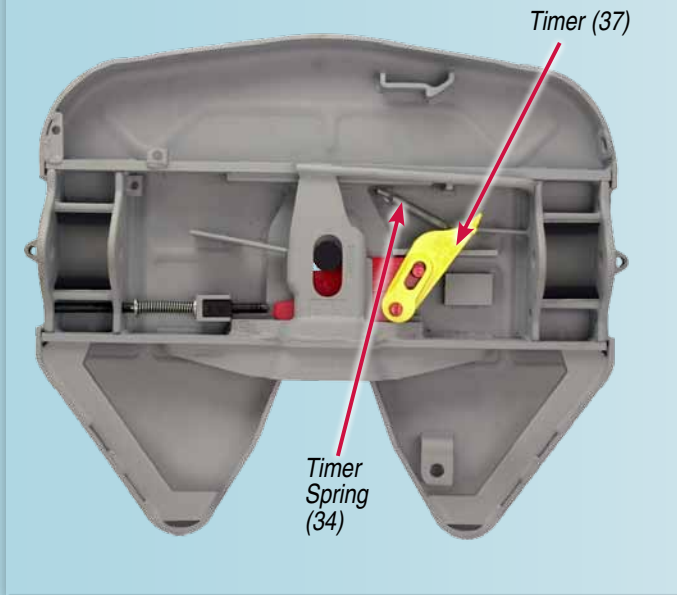

6. Remove jaw and wedge

Remove jaw (35) and wedge (36).

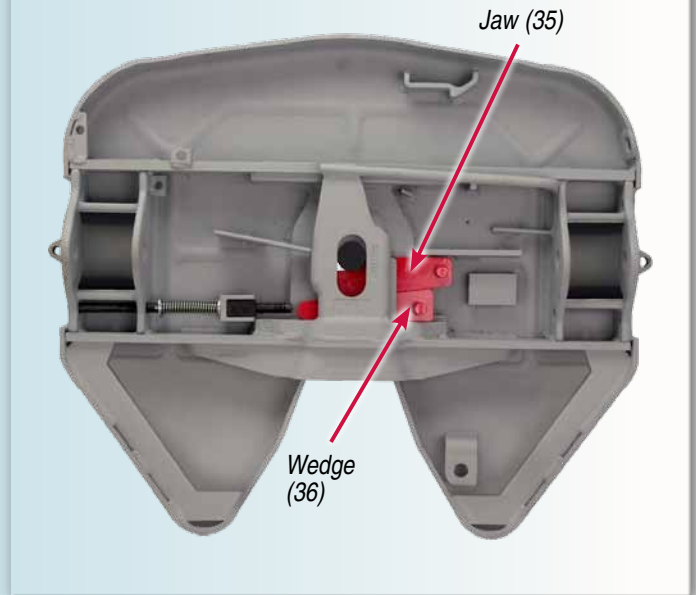

Fontaine No-Slack® non-genuine parts advisory

The purpose of this notice is to alert Fontaine customers of the potential hazards from using non-genuine components, specifically the movable locking jaw and wedge. Recent reports have revealed the sale, use and failure of these components. Failures are occurring as a result of the locking wedge stud falling out (see photo in red) at an early cycle time which affects the proper opening and closing of the mechanism,

and could create a dangerous condition. The non-genuine components are easy to identify by the physical characteristics listed below. The use of any non-genuine components not only creates a potential dangerous condition, it also voids the manufacturer's warranty. **The seller and end user assume any/all responsibility for warranty, property and bodily damage as a result of using non-genuine parts.**



Non-genuine parts



- The non-genuine parts come in a white box.
- The non-genuine parts have jaw and wedge studs that are pressed/glued into the forging. A picture of the failed part is shown above.

Genuine Fontaine No-Slack® parts



- Genuine Fontaine parts come in a small brown box with Fontaine part number KIT-RPR-6000L clearly printed on a white label (photo of box above).
- Genuine Fontaine parts have the model number forged into the jaw and wedge forging.
- Only Genuine Fontaine parts have "Genuine Fontaine Parts" printed on the box.

Before rebuilding the assembly, check to make sure that there are no cracks in the casting or other components. Also check bracket pin holes to ensure they are not worn oversize (pins should fit snugly). Refer to exploded view of assembly on page 6 to identify item number and parts.

Adequate lubrication should be used

1. Insert jaw and wedge

Always assemble parts around a 2" kingpin or a 2" diameter shaft. Insert jaw (35) first and then the wedge (36) below it. Grease the jaw and wedge on top and bottom.

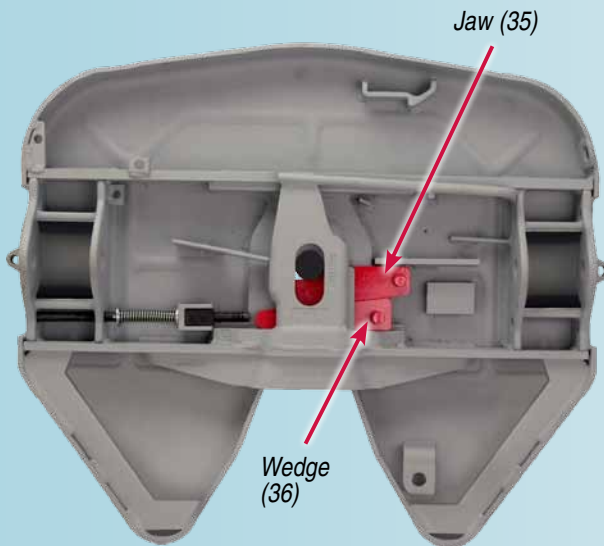

Note: 7000 top plate shown, but similar to Ultra NT

2. Insert timer

Insert timer (37) and timer spring (34).

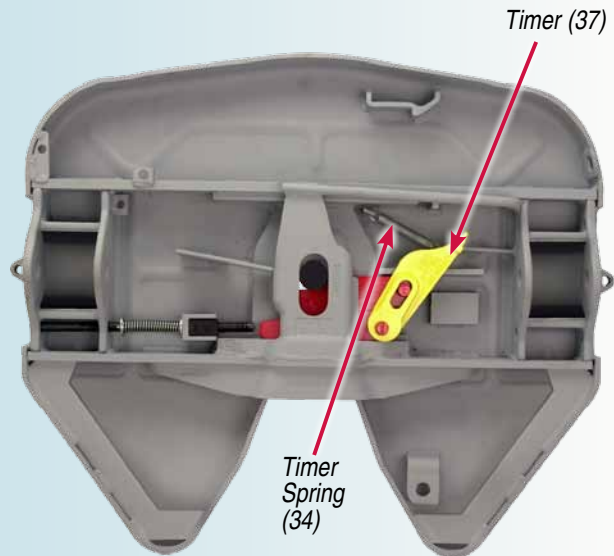

3. Insert operating handle

Insert operating handle (38) and bolt (43) to pivot mount on fifth wheel. Use existing bolt (43), washers (41) and hairpin cotter (39). Inspect for wear before using and replace if necessary. Use the new lock nut (40) and bushing (42) that is supplied in the repair kit.

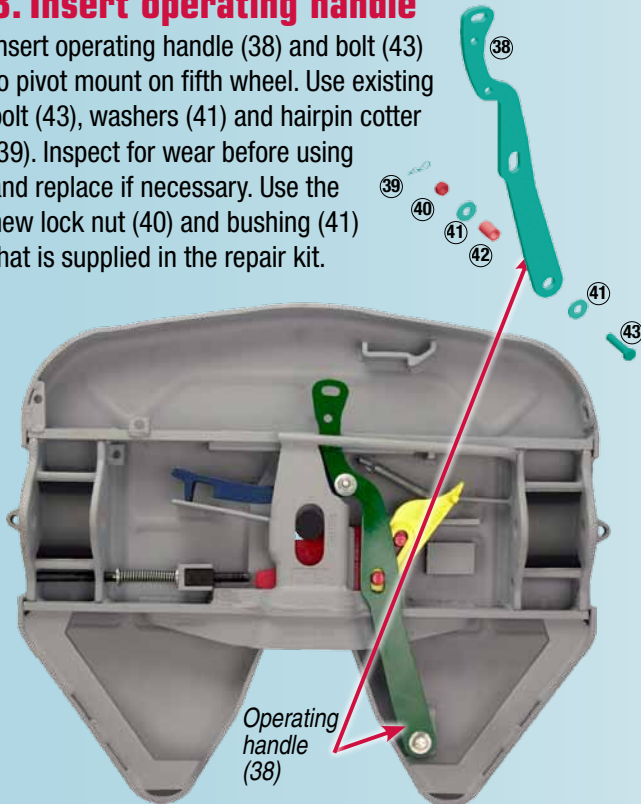

4. Install bumper

Install bumper (33) and bolt (29) to operating handle (38). Use existing bolt (29) and washers (30) (inspect for wear before using and replace if necessary). Use new lock nut (32) and bushing (31) that is supplied in the repair kit. Note orientation of bolt (29). Threads should be facing up. After installing the bumper check to make sure that it can pivot freely.

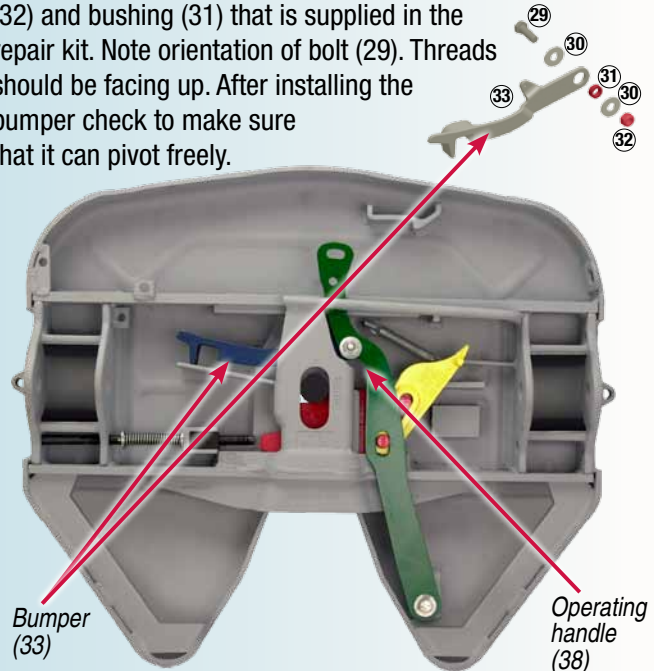

Refer to exploded view of assembly on page 6 to identify item number and parts.

5. Attach the secondary lock

Insert secondary lock (24) and bolt (21) to operating handle (38). Use existing bolt (21) and washers (22) (inspect for wear before using and replace if necessary). Use new lock nut (25) and bushing (23) that is supplied in the repair kit. Note orientation of bolt (21). Thread should be facing down.

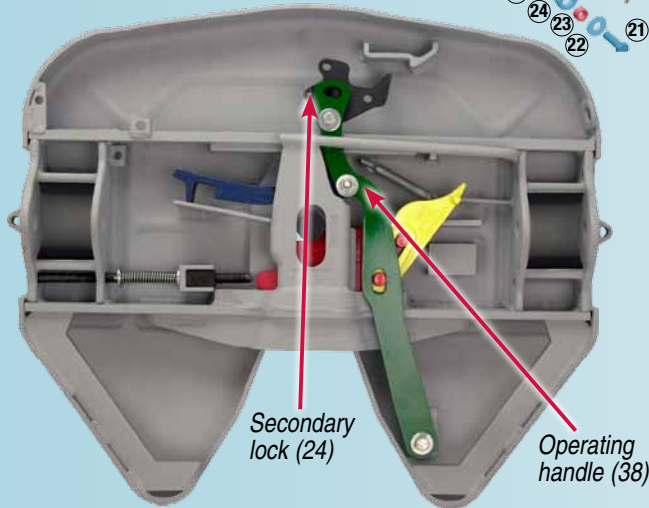

6. Attach pull handle

Install pull handle (26). Use existing washer (27) and cotter pin (28). Inspect for wear before using and replace if necessary. Attach new secondary lock (24) and bumper spring (12) that is supplied in the repair kit. Now open and close the wheel to ensure that it works properly. Fifth wheel must be properly lubricated before opening and closing the wheel.

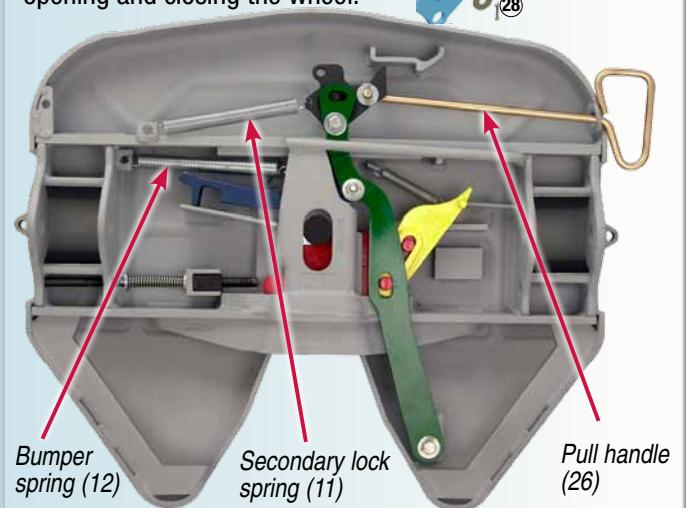

Air cylinder models

Your Ultra NT fifth wheel can easily be converted to an air actuated release model. Order Part No. "KIT-AA-?". Specify left side (driver's side) or right side (curb side) release by adding an "L" or "R" after Part #. See more detailed instructions on page 7. **Need new kit # for L and R**

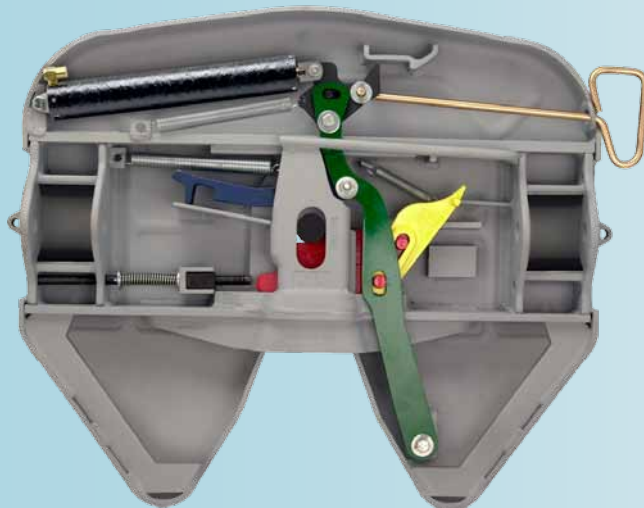

Adjust fifth wheel

Open the fifth wheel, insert a 2" kingpin and close the wheel. Turn the adjustment rod (4) clockwise (inward) until it contacts the end of the locking wedge (36). Close the fifth wheel several times with a standard 2" kingpin tool. With the lock closed, adjust the wedge-stop rod (4) so that the end is 1/4" from the wedge (36). The fifth wheel should operate freely and smoothly without binding or interference.

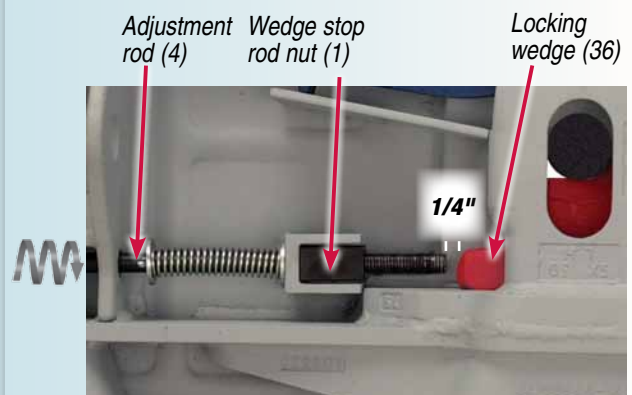

Ultra NT rebuild diagram

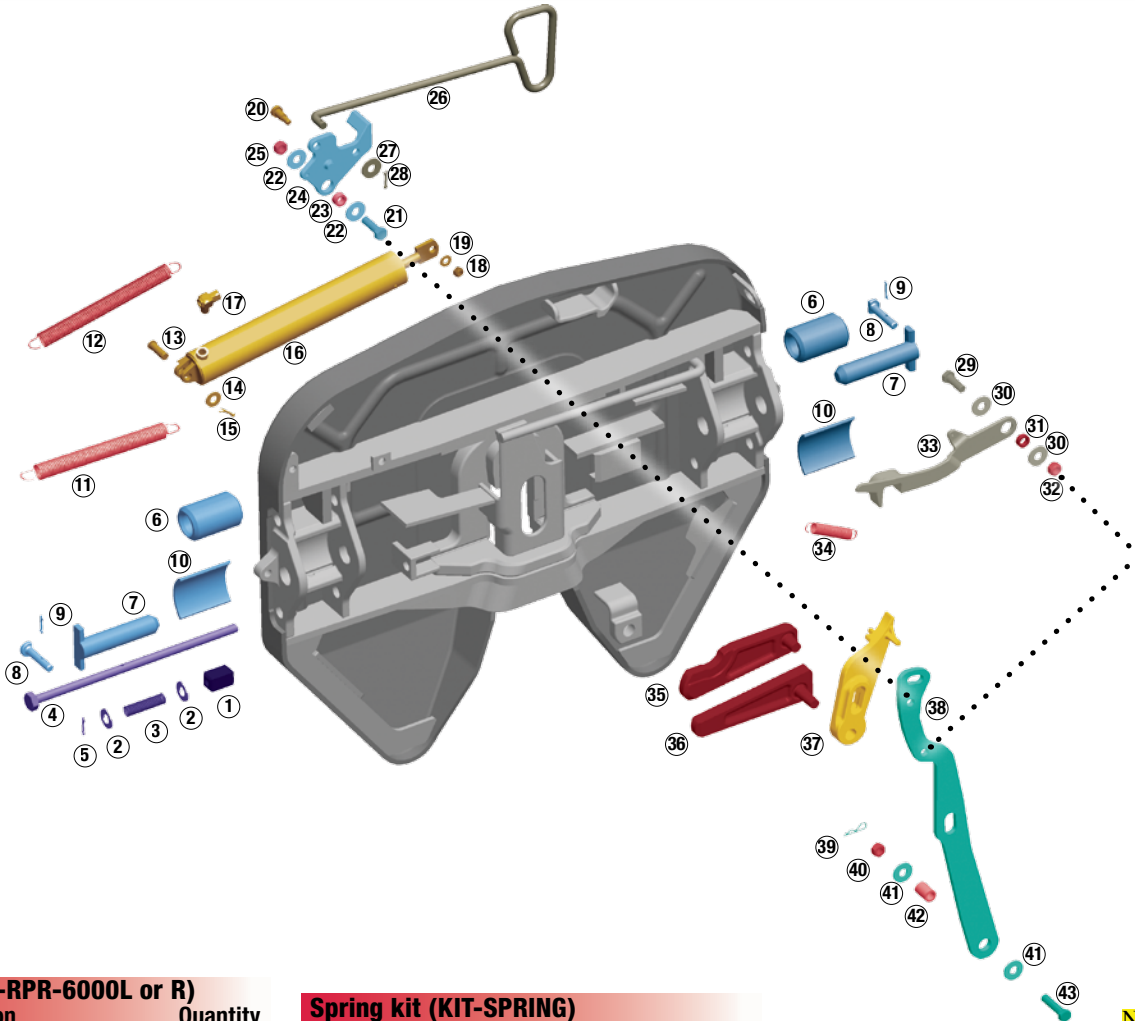

Rebuild kit (KIT-RPR-6000L or R)

Item	Description	Quantity
11	Bumper spring	1
12	Handle spring	1
34	Timer spring	1
35	Step jaw	1
36	Wedge	1
23	Bushing, 7/16"	1
31	Bushing, 5/16"	1
42	Bushing, 1 1/4"	1
25 32 40	Hex lock nut, 1/2" - 13	3

Wedge-stop rod kit (KIT-ROD-1108)

1	Wedge-stop rod nut	1
2	Flat washer, 5/8" I.D.	2
3	Wedge-stop rod spring	1
4	Wedge-stop rod	1
5	Cotter pin, 3/16" x 1"	1

Bracket pin kit (KIT-PIN-UNT)

6	1-piece bushing	2
7	Bracket pin	2
8	Bracket retainer pin	2
9	Cotter pin	2
10	Bracket Liner	2

Secondary lock kit (KIT-LAT-6000L or R)

12	Handle spring	1
21	Hex head bolt, 1/2" - 13	1
22	Flat washer, 1/2" I.D.	2
23	Bushing, 7/16"	1
24	Secondary lock	1
25	Hex lock nut, 1/2" - 13	1
28	Cotter pin, 3/16" x 1"	1

Spring kit (KIT-SPRING)

Item	Description	Quantity
11	Bumper spring	1
12	Handle spring	1
34	Timer spring	1

Bumper kit (KIT-BPR-6000L or R)

32	Hex lock nut, 1/2" - 13	1
30	Flat washer, 1/2" I.D.	2
31	Bushing	1
29	Hex head bolt, 1/2" - 13	1
33	Bumper	1
11	Bumper spring	1

Timer kit (KIT-TMR-6000L or R)

34	Timer spring	1
37	Timer	1
40	Hex lock nut, 1/2" - 13	1
39	Hair pin cotter	1

Operating handle kit (KIT-OPR-6000)

23	Bushing, 7/16"	1
31	Bushing, 5/16"	1
42	Bushing, 1 1/4"	1
25 32 40	Hex lock nut, 1/2" - 13	3
40	Flat washer, 1/2" I.D.	2
43	Hex head bolt, 1/2" - 13	1
38	Operating handle	1
39	Hair pin cotter	1

Pull handle kit (KIT-PUL-6000L or R)

26	Pull handle	1
27	Flat washer, 1/2" I.D.	1
28	Cotter pin, 3/16" x 1"	1

Need new kit # for L and R

Air actuated kit (KIT-AA-?? C...)
 This kit includes the parts mounted to the fifth wheel. If you are upgrading from manual to air actuated you will also need KIT-AIR-DASH which includes the parts required to complete the in-dash installation.

Item	Description	Quantity
13	Pin	1
14	Flat washer	1
15	Cotter pin	1
16	Air cylinder	1
17	Mini-matic jumbo exhaust valve	1
18	Hex lock nut	1
19	Flat washer	1
20	Shoulder bolt	1

KIT-AIR-DASH



Ultra NT diagram key & air cylinder installation

Item	Description	Quantity
①	Wedge-stop rod nut	1
②	Flat washer, 5/8" I.D.	2
③	Wedge-stop rod spring	1
④	Wedge-stop rod	1
⑤	Cotter pin, 3/16" x 1"	1
⑥	1-piece bushing	2
⑦	Bracket pin	2
⑧	Bracket retainer pin	2
⑨	Cotter pin	2
⑩	Bracket Liner	2
⑪	Bumper spring	1
⑫	Handle spring	1
⑬	Pin	1
⑭	Flat washer	1
⑮	Cotter pin	1
⑯	Air cylinder	1
⑰	Mini-matic jumbo exhaust valve	1
⑱	Hex lock nut	1
⑲	Flat washer	1
⑳	Shoulder bolt	1
㉑	Hex head bolt, 1/2" - 13	1
㉒	Flat washer, 1/2" I.D.	2
㉓	Bushing, 7/16"	1
㉔	Secondary lock	1
㉕	Hex lock nut, 1/2" - 13	1
㉖	Pull handle	1
㉗	Flat washer, 1/2" I.D.	1
㉘	Cotter pin, 3/16" x 1"	1
㉙	Hex head bolt, 1/2" - 13	1
㉚	Flat washer, 1/2" I.D.	2
㉛	Bushing, 5/16"	1
㉜	Hex lock nut, 1/2" - 13	1
㉝	Bumper	1
㉞	Timer spring	1
㉟	Step jaw	1
㊱	Wedge	1
㊲	Timer	1
㊳	Operating handle	1
㊴	Hair pin cotter (not pictured)	1
㊵	Hex lock nut, 1/2" - 13	1
㊶	Flat washer, 1/2" I.D.	2
㊷	Bushing, 1 1/4"	1
㊸	Hex head bolt, 1/2" - 13	1

Air cylinder installation instructions:

1. Remove fifth wheel from mounting brackets. Cleaning the fifth wheel before installing the kit is recommended.
2. Place the fifth wheel in the upside down position. Make sure that the fifth wheel is placed on a suitable work surface.
3. Remove the old bumper spring (11) and pull handle spring (12) from the fifth wheel. See Diagram 1.
4. Install the exhaust valve (17) into the new cylinder. Make sure valve is oriented as shown. See Diagram 1 for spring locations.
5. Install the new air cylinder (16). Note positions of pin (13) and bolt (20). Orient cylinder as shown in Diagram 2.
6. Install the new bumper spring (12) and pull handle spring (11). See Diagram 1.
7. Reinstall the fifth wheel back on the mounting brackets.
8. Insert the airline supply into the quick disconnect on the exhaust valve.
9. Open and close the fifth wheel using the air cylinder to ensure proper function.
10. Tilt the fifth wheel forward to ensure that the cylinder and/or air supply line does not interfere with another component. (Please see diagram 3)

Note: Valves and airline are available through Fontaine. Order a KIT-AIR-DASH for mounting the pull valve in the dash and plumbing the airline to the cylinder.

Diagram 1

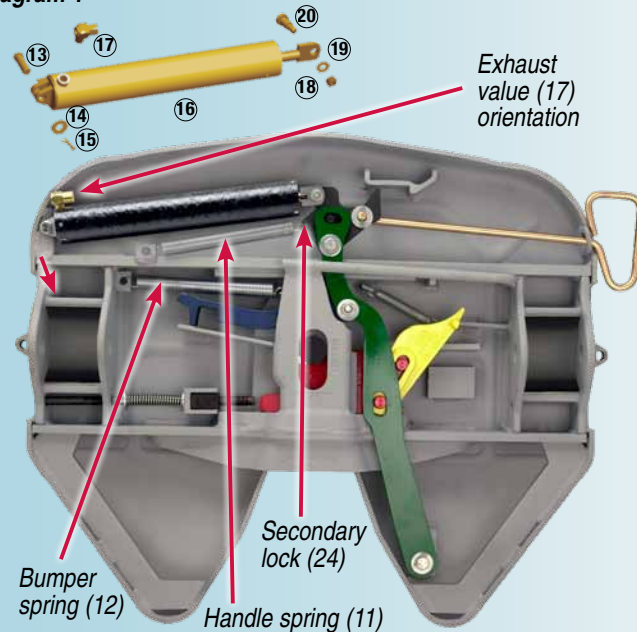

Diagram 2

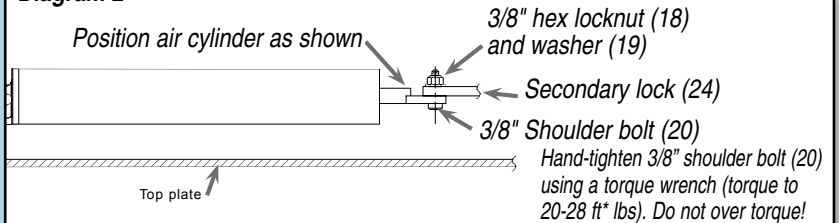
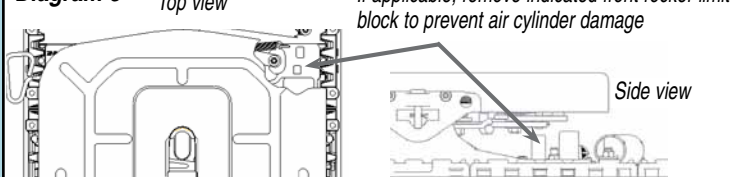

Diagram 3



Items needed for rebuild

Remember to exercise extreme caution, follow all stated & customary safety procedures, and be sure to wear safety glasses.

Do not use pneumatic tools. Over-tightening may cause damage.

- 3/4" wrench
- 3/4" socket wrench
- 1 1/16" wrench
- Pliers
- Flat head screw driver
- Long pry bar
- Test kingpin MSC-712
- Kingpin gauge MSC-GAUGE
- Moly-based lubricant such as Mobilgrease XHP320 or equivalent

Handy tools available from Fontaine Parts Connection

Fontaine offers special tools for your fifth wheel to help your repairs go fast and easy.



Test kingpin for all Fontaine fifth wheels
KIT-ULTRA-KP

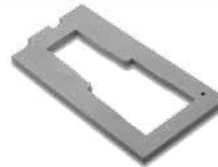

Kingpin gauge
MSC-GAUGE

Air actuated in-cab release

You can upgrade your Fontaine 6000 or 7000 series fifth wheel from manual to "Air Actuated" in-cab release. Simply order a **KIT-AA-6000L** (road side release) or **KIT-AA-6000R** (curb side release). You will also need **KIT-AIR-DASH** for the parts required to complete the in-dash installation.



Top plate rebuild kit

No-Slack rebuild kits for ULTRA NT/6000/7000/7000CC top plates

*KIT-RPR-6000L (left release)
KIT-RPR-6000R (right release)*



Above is most common kit. After inspection you may need to optionally order other kits. See schematic on page 6.